

CROSS-SECTION	INFORMATION
	<p>temp. class: 3M1 working temp.: -1/+5 C power supply: 230V/50Hz refrig. supply: PLUG-IN refrigerant: R290 defrosting: air fans: electrical lighting: horizontal no of rows: 2 single kind of lighting: LED doors: tempered double glass (4 +10 +4) type: hinged opened: left/right</p>

EXPOSITION SURFACES

surface	*	rows number	product	width [mm]	load height [mm]	angle [°]	load [kg/m ²]
hanged shelf	1	5	normal	450	180	0	35
bottom shelf	2	1	normal	510	180	0	55

CHARACTERISTIC

module	*	[-]	2500
module length	3	[mm]	2500
module height	4	[mm]	2000
module width	5	[mm]	900
display height	6	[mm]	1615
display opening area	7	[m ²]	4.04
total display area (TDA)	8	[m ²]	4.04
visibility of products (VPA)	9	[m ²]	1.80
net volume	10	[dm ³]	1242.00
refrigerated shelf area	11	[m ²]	6.90
net weight	12	[kg]	463

NOTICE

* development version

The information included in the Technical Data of device refers to certain equipment defined in the first page. All values and parameters are defined on the basis of standard PN EN ISO 23953 for the given temperature class, range of temperature and equipment

RECOMMENDATIONS

The correct work of devices enables its non-failure work with energetical rated parameters

Complying with the rules of device loading guarantees the stable temperature parameters of stored products. Properly selected operating parameters allow you to greatly reduce the cost of electricity consumption.

THE MANUFACTURER RESERVES THE RIGHT TO ALTER THE FEATURES AND TECHNICAL SPECIFICATIONS OF ITS PRODUCTS.

AMBIENT PARAMETERS			
1	climate class	-	3
2	max. ambient temperature	[°C]	25
3	max. ambient humidity	[%]	60
4	illumination	[lux]	200
5	max. ambient air speed	[m/s]	0.2

DEVICE WORKING PARAMETERS			
6	device temperature class	-	M1
7	cabinet temperature	[°C]	-1/+5
8	refr. evaporating / condensing temp.	[°C]	-8/+45 C
9	suction superheat	[K]	5
10	refrigerant	R290	

COOLING DATA			
module	*	[-]	2500
unit cooling capacity	11	[W]	1284
inlet tube	13	[mm]	15
outlet tube	14	[mm]	18
refrigerant fluid	15	[kg]	0.15

ELECTRICAL DATA			
module	*	[-]	2500
power supply	16	[V/Hz]	230/50
compressor	17	[W]	632
	18	[A]	3.10
defrosting, hot gas	19	[W]	0
	20	[A]	0.00
fans	21	[W]	76
	22	[A]	0.37
lighting	23	[W]	75
	24	[A]	0.37
heaters	25	[W]	0
	26	[A]	0.00

RATED DATA			
module	*	[-]	2500
power rate, current	27	[W]	783
	28	[A]	3.84

ELECTRICAL CONSUMPTION			
module	*	[-]	2500
TEC	29	[kWh/24h]	7.05
AE	30	[kWh/a]	2572.16
EEl	31		12.15 Energy Class: B

WORKING PARAMETERS						
32	defrosting time	[h/24h]	3	34	working time of heaters	[h/24h]
33	working time of fans	[h/24h]	12	35	working time of lighting	[h/24h]
						12

PARAMETERS OF ELECTRICAL TERMINALS						
36	power supply P+N+PE	[V/Hz]	230/50	37	electrical connection - plug-in socket	230V/16A

TEC - TOTAL ENERGY CONSUMPTION EEI - ENERGY EFFICIENCY

NOTICE

In the devices with night curtain or covers, the covering time is 12h.

CONTROLLING PARAMETERS

1	set point ST	[°C]	0	6	correction ST by night	[°C]	-
2	differential ST	[°C]	2	7	defrosting number	[lit/24]	4
3	set point correction ST	[°C]	-	8	temperature of defrosting end	[°C]	8
4	fan running during defrosting	[yes/no]	yes	9	maximum time of defrosting	[min]	45
5	stop fans temperature	[°C]	-	10	dripping time	[min]	0

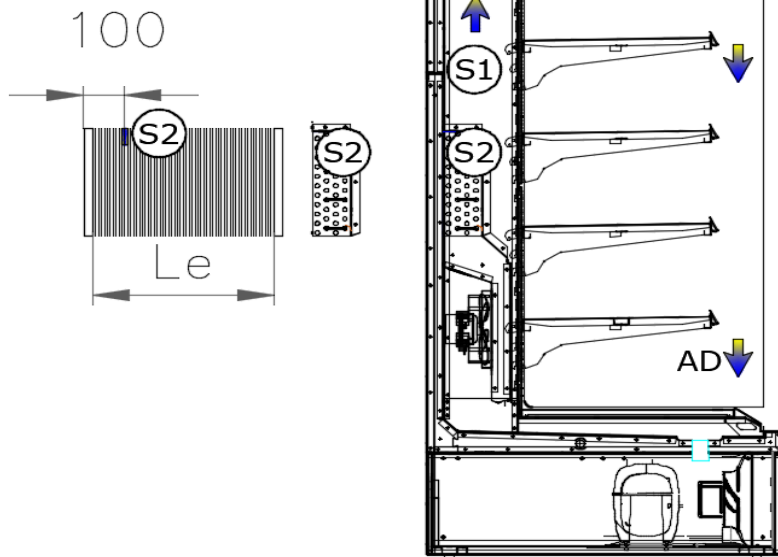

1 - LOCALIZATION OF CONTROL PROBE

2 - LOCALIZATION OF DEFROSTING PROBE, DEFROSTING HEATERS

lm - MODULE LENGTH

S1 - CONTROL PROBE

S2 - DEFROSTING PROBE

le - LENGTH OF EVAPORATOR

Hd - DEFROSTING HEATER

EV - EXPANSION VALVE

AD - AIR FLOW DIRECTION

Notice

Automatic control system should ensure deicing from evaporator and removal of water.

The devices in line must be controlled dependently. The control system of particular devices in line must synchronize the start and end of defrosting process





The defrosting process should be managed by temperature. 9-th parameter should be treated as emergency.

If the parameter number 4 is set on "no" value, the fans work depends on temperature value of defrosting probe (parameter no 5). During the dripping time of evaporator the fans dont work.

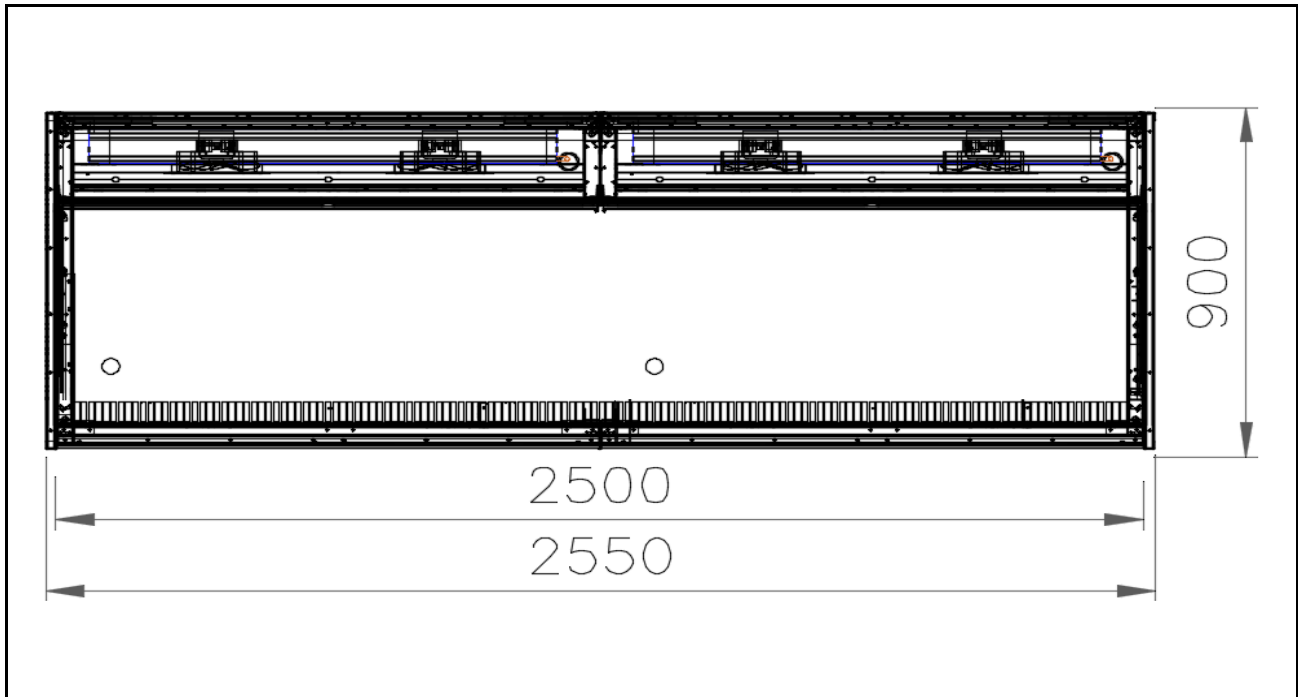
The correction set point by night ensures the correct device work with closed curtains. The parameter beneficially influences energy savings.

If it is necessary, please modify parameters to provide good work of device.



 REFRIGERATION CONNECTION UNDER DEVICE  UPPER REFRIGERATION CONNECTION	 ELECTRIC CONNECTION UNDER DEVICE  UPPER ELECTRICAL CONNECTION	 CONDENSAT WATER DRAINAGE
<p> </p>		
<p>NOTICE To arrange a device you need to ensure its correct ventilation. The surfaces of side glass must be moved from walls in order to guarantee air flow to dry them. To ensure the correct work the refrigeration devices must be moved from a wall on the distance of 50mm (remote device) and 100mm (plug-in). THE MANUFACTURER RESERVES THE RIGHT TO ALTER THE FEATURES AND TECHNICAL SPECIFICATIONS OF ITS PRODUCTS.</p>		